

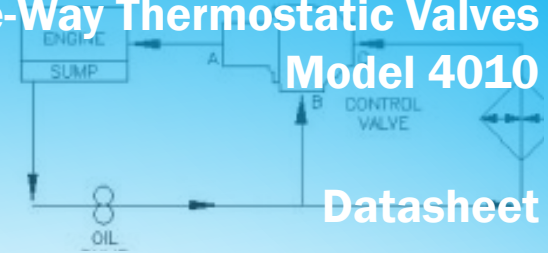

Three-Way Thermostatic Valves Model 4010

Datasheet

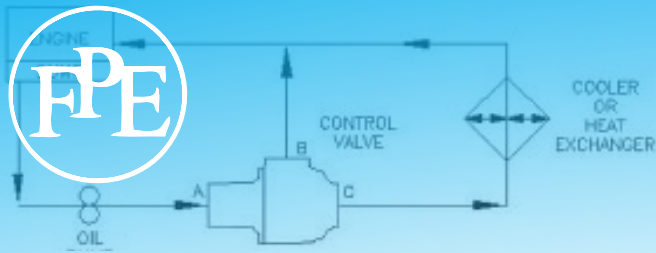

Including:

- 4010 4" Flange
- 4010M 4" Flange with manual override

Features and Benefits

- Wide range of temperatures
- Heavy duty
- Self-contained
- Replaceable element
- Non-adjustable
- Rugged construction
- Tamper-proof
- Operate in any position
- Compact



Compact, reliable temperature control

Fluid Power Energy (FPE) thermostatic valves use the principle of expanding wax, which in the semi-liquid state undergoes large expansion rates within a relatively narrow temperature range. The self-contained element activates a stainless steel sleeve, which directs flow. All FPE thermostatic valves are factory set at predetermined temperatures: no further adjustments are necessary. A wide range of temperatures are available for water and oil temperature control applications.

When used in a diverting application, on start-up the total fluid flow is routed back to the main system. As fluid temperature rises to the control range, some fluid is diverted to the cooling system. As fluid temperature continues to increase, more flow is diverted. When the thermostat is in a fully stroked condition, all fluid flow is directed to the cooling system. FPE thermostatic valves may also be used in a mixing application.

In a mixing application, hot fluid enters the "B" port and colder fluid enters the "C" port. The flows mix and the thermostat adjusts to reach the desired temperature, exiting the "A" port.

Standard FPE thermostatic valve housings are made from aluminum and grey iron castings, however, ductile iron, bronze, steel and stainless steel housings are available.

Available Connections: 125# FF Flange, 150# RF Flange, 300# RF Flange, Navy and Metric Flanges.

Optional features: Manual Override, High Over Temp element, Plated element. Other options available upon request.

Model 4010 Three-Way Thermostatic Valve

Specification

Model Number	Body Material (*)	Nominal Pipe Size	Principal Dimensions Units - inches (mm)				Max. width in other plane	Flange Drilling			No. of elements	Approx. shipping weight	Notes for numbered end notes
			"X"	"Y"	"W"	"Z"		No. of holes	Dia. of holes	Bolt circle			
*4010	A, B, D	4" 125# FF Flange	N/A	7 15/16 (201.61)	15 7/8 (403.23)	8 9/16 (217.49)	11 (279.40)	8	3/4 (19.05)	7 1/2 (190.50)	4	A=95#, B=116#, D=90#	
	S, SS	4" 150# RF Flange	N/A	7 15/16 (201.61)	15 7/8 (403.23)	8 9/16 (217.49)	11 (279.40)	8	3/4 (19.05)	7 1/2 (190.50)	4	S & SS=104#	
*4010M	A, B, D	4" 125# FF Flange	N/A	7 15/16 (201.61)	15 7/8 (403.23)	8 9/16 (217.49)	11 (279.40)	8	3/4 (19.05)	7 1/2 (190.50)	4	A=97#, B=118#, D=92#	Manual override
	S, SS	4" 150# RF Flange	N/A	7 15/16 (201.61)	15 7/8 (403.23)	8 9/16 (217.49)	11 (279.40)	8	3/4 (19.05)	7 1/2 (190.50)	4	S & SS=106#	Manual override
*4010X	S, SS	4" 300# RF Flange	N/A	7 15/16 (201.61)	15 7/8 (403.23)	8 9/16 (217.49)	11 (279.40)	8	7/8 (22.23)	7 7/8 (200.03)	4	S & SS=126#	
*4010XM	S, SS	4" 300# RF Flange	N/A	7 15/16 (201.61)	15 7/8 (403.23)	8 9/16 (217.49)	11 (279.40)	8	7/8 (22.23)	7 7/8 (200.03)	4	S & SS=127#	Manual override

* Replace * with body material type: A = Cast iron, B = Bronze, D = Ductile iron, S = Steel, SS = Stainless Steel

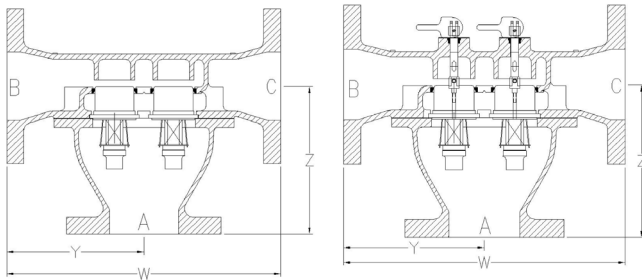

*4010, *4010X

*4010M, *4010XM

Pressure Ratings	
Material	PSI
A	150
B	125
D	200
S, SS	275
SX, SSX	720

Flow vs. Pressure Drop

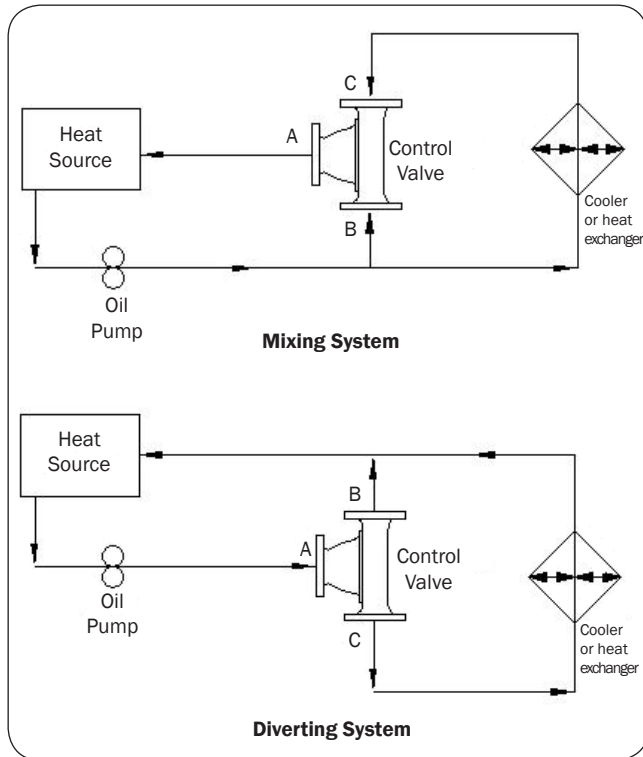
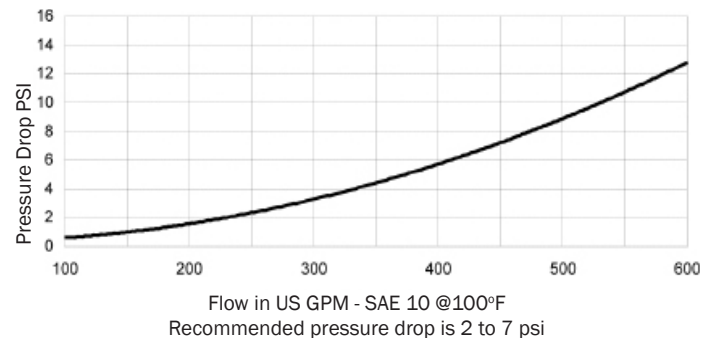

Spare Parts

Part Number	Description
*4010	Valve body (*See table for material)
*4020	Valve cover (*See table for material)
2071	Lip seal
4080-C	Gasket
2050-Temp	Thermostat (Temp to follow dash)
1604	Hex bolt
1605	Lock washer
1590	Nameplate
FPE Model 4000	Replacement kit (includes the following:)
4080C	Gasket
(4) 2071	Lip seal
(4) 2050-Temp	Thermostat (Temp to follow dash)

Americas

Global Headquarters
Fluid Power Energy Inc
W229 N591 Foster Court
Waukesha, WI 53186
USA

Tel: +1 262-548-6220
Fax: +1 262-548-6239
Email: fpeinfo@fpevalves.com

Europe, Middle East, Africa, India, Russia & Asia Pacific

Fluid Power Energy Inc
Steinackerstraße 20
D-79576 Weil am Rhein
Germany

Tel: +49 (0)7621 940 9990
Fax: +49 (0)7621 940 99940
Email: info@fpevalves.de

Peoples Republic of China

FPE (Shanghai) Industry Co., Ltd
2F 5#Building No.166 Mindong Rd,
Pudong, Shanghai,201209
China

Tel: +86 (0)21 6163 0930
Fax: +86 (0)21 6163 0930
Email: jerry@fpevalves.com



www.fpevalves.com