



Spin-Clean™ Oil Cleaning Centrifuge Model M300

Datasheet

Including:

- Parts List
- Installation and Operation
- Service Instructions

Features and Benefits

- True centrifuge
- Reduces hazardous waste
- Extends oil and filter life
- Removes solid below one Micron
- Diagnostic tool
- User friendly
- Easy installation
- Rugged construction



Parts List

Model M300

Parts List

Description	Part No.
Cover Assembly (no clamp)	C300-CA
Pin-Cover Nut	C300-12
Knob-Cover Nut	C300-14
Cover	C300-15
Seal-Cover Nut	C300-09
Nut-Cover	C300-13
Clamp w/ Tee Handle-Cover to Base	C300-18
Centrifuge Turbine Assembly	C300-TA
Nut-Turbine	C300-11
Cover-Turbine	C300-03
Seal-Turbine (2 req'd)	C300-10
Insert-Turbine (Package of 25)	C300-33P
Bowl-Turbine	C300-02
Baffle-Turbine	C300-04
Base, Turbine Assembly (sold as assembly only)	C300-BTA
Nozzle-Turbine (2 req'd)	C300-19-20
Base Assembly (no clamp)	C300-MBA
Seal, Base to Cover	C300-17
Base/Shaft (sold as assembly only)	C300M-16-A
Model 300 Service Tool Kit	C300-SK

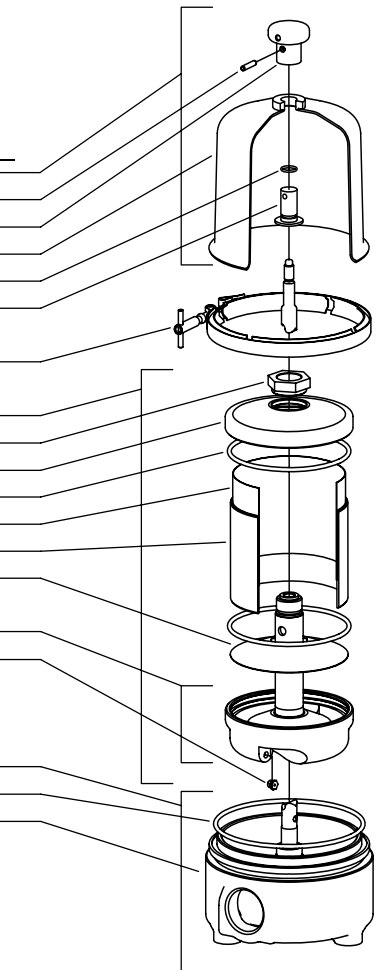

Installation and Operation

Oil Supply to Centrifuge

Oil supply should be taken from a source as close to the lube oil pump discharge as possible and on the dirty side of the full flow oil filter. A 1/2" NPT pipe or #8 hose supply should be used for supply with a full-opening ball valve installed in supply line to allow the centrifuge to be isolated for cleaning without shutting the engine down. The centrifuge will operate efficiently at 30 to 90 psig with the preferred pressure of 60 to 80 psig. Below 30 psig, an internal idle cutout valve will close to prevent low oil pressure during low engine RPM.

Clean Oil Return to Sump

Using Oil Control Base (OCB) Preferred

The oil control base, **Part # COCB-01** permits the Model 300 centrifuge to be installed in any convenient location near the engine.

The clean oil drain line to the sump should be a 1" minimum diameter, unrestricted hose or pipe. A 1" connection located above the oil level is preferred. Alternate oil fill openings or drilled-and-tapped holes in crankcase doors are options that can be used. A below oil-level-return will require the use of a 1 1/2" check valve, **Part # C300-24**, located at the OCB oil outlet connection to prevent back-flow when the centrifuge is being serviced. Only low pressure drop check valves are permitted in the drain line, manual shut-off valves should never be used on the drain line.

The OCB controls the oil flow from the centrifuge back to the engine and insures the centrifuge reaches maximum speed and efficiency. To accomplish this, the OCB uses a very small volume of compressed air; approximately 0.02 SCFM. The OCB is capable of receiving compressed air from any 5 to 400 psig source. If there is no compressed air available it may be possible to use turbocharger air or air from a positive displacement blower. Instructions for this type installation are available from your SPIN-CLEAN™ representative.

Using Gravity Drain Engine Mounting Only

For gravity drain without the OCB, the SPIN-CLEAN™ centrifuge must be close-coupled to the engine sump using an unrestricted 2" I.D. drain back into the engine above the engine normal oil level. A crankcase door, inspection cover, etc. can be modified to provide a suitable oil return back into the engine. The drain is correct if you can drop in a 4" diameter ball and it can freely roll through the drain line into the engine.

Mounting Considerations

SPIN-CLEAN™ Centrifuges are high-speed devices and should be securely mounted to prevent excessive vibration. Model 300 may be installed up to 15 degrees from vertical.

UNIT WEIGHT: 30 LBS [13.6 kg]

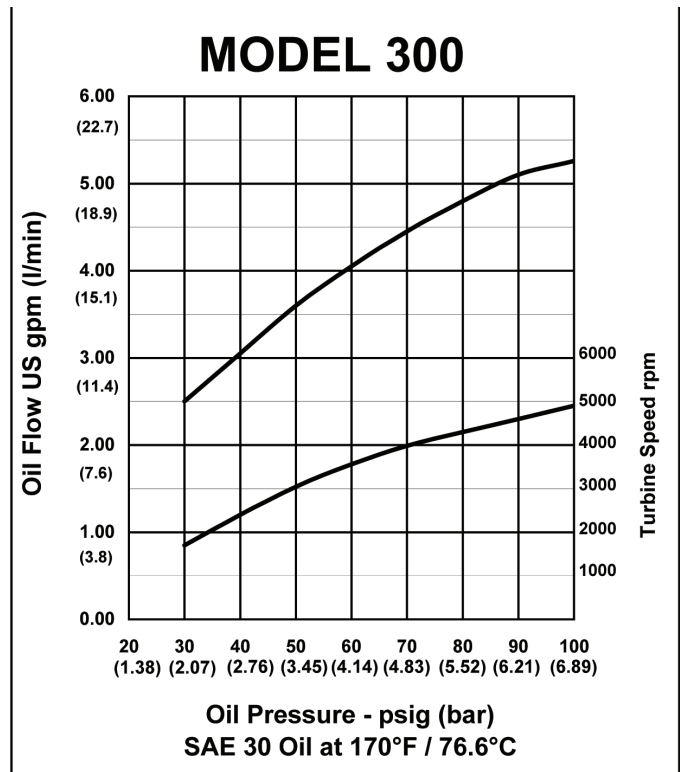
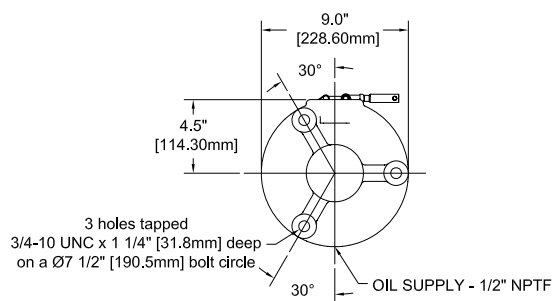
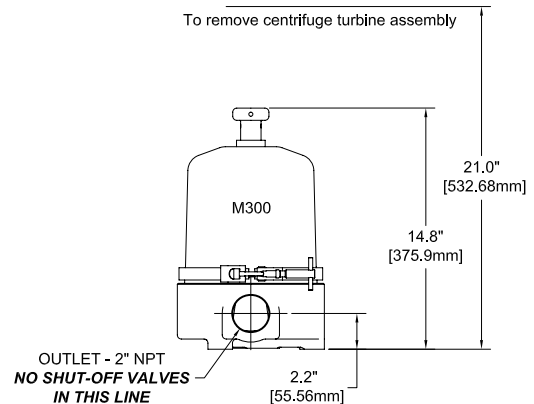

Service Instructions

1. Shut off oil supply or stop the engine and allow centrifuge turbine assembly to come to a complete stop. Caution: Open safety bleed valve on side of the Oil Control Base (if equipped) and be certain that the unit is not pressurized. If safety bleed valve is under pressure, locate the source and remove before proceeding. **The oil drain line should be free of any shut-off valves.**

2. Remove cover clamp, unscrew cover and remove cover assembly.

3. Lift the turbine assembly a couple of inches and allow the oil to completely drain out of the nozzles before removing completely. Carefully separate the turbine assembly.

Do not strike the bushings with or against a hard surface or damage will result. Remove lower turbine bowl seal and then remove baffle.

4. Carefully remove the solid cake from the turbine bowl, **Part # C300-02**, taking care not to damage the turbine bowl. Thoroughly wash away all traces of the solid cake to insure maintaining turbine balance.

5. Thoroughly clean all other turbine parts. Check turbine nozzles and make sure they are unrestricted. Inspect turbine bowl seals, **Part # C300-10**, for cuts or damage; they can be used several times. Examine top and bottom bearings for excessive wear. Replace turbine base assembly, **Part # C300-BTA**, if diameters exceed 0.503" (12.8 mm) top or 0.879" (22.3 mm) bottom.

6. Seat baffle in turbine base and install lower turbine bowl seal, **Part # C300-10**, in the turbine base. Install turbine insert, **Part # C300-33**, inside the turbine bowl. Reassemble the turbine assembly tightening the bowl nut securely using finger pressure only.

7. Examine stationary shaft journals for damage or excessive wear. Replace base assembly, **Part # C300-BA**, if diameter is less than 0.496" (12.6 mm) top or 0.871" (22.1 mm) bottom. The stationary shaft is permanently installed and cannot be replaced.

8. Remove, clean and inspect the idle-cut-out-valve assembly and mating bore in housing. The piston should move freely in the bore. If damaged replace with **Part # C300-27**.

9. If OCB is used check for proper mechanical operation and structural integrity.

10. Coat the stationary shaft with clean oil. Install the turbine assembly on the stationary shaft, being careful not to damage bearings. Spin turbine assembly on the stationary shaft and make sure it spins freely and unrestricted.

11. Clean and inspect cover and make sure the cover seal, Part # C300-09, is not leaking. If necessary, replace the seal by removing the roll pin below the hand knob and remove the nut from the bottom.

12. Inspect the base to cover seal, **Part # C300-17**, and replace if necessary.

13. Replace the cover assembly and tighten the cover knob by hand pressure plus another half turn. Make sure the cover seats on the base evenly all around to insure proper crush on cover seal to prevent oil leaks. Reinstall the cover clamp and tighten securely.

14. Close safety bleed valve on the Oil Control Base. Turn on air supply and oil supply to the centrifuge. With engine running, check complete installation for oil leaks or excessive vibration. If excessive vibration exist then disassemble, inspect and reassemble.

Note: All centrifuge turbines are factory tested for balance before leaving the factory. An out-of-balance condition can occur as a result of uneven build up of dirt cake in the bowl or as a result of excessive bearing or stationary shaft wear. Depending on conditions, wear will eventually take place on the stationary shaft and bearings, requiring replacement of the appropriate assemblies.

Americas

Global Headquarters
Fluid Power Energy Inc
W229 N591 Foster Court
Waukesha, WI 53186
USA

Tel: +1 262-548-6220
Fax: +1 262-548-6239
Email: fpeinfo@fpevalves.com

**Europe, Middle East, Africa,
India, Russia & Asia Pacific**

Fluid Power Energy Inc
Steinackerstraße 20
D-79576 Weil am Rhein
Germany

Tel: +49 (0)7621 940 9990
Fax: +49 (0)7621 940 99940
Email: info@fpevalves.de

Peoples Republic of China

FPE (Shanghai) Industry Co., Ltd
2F 5#Building No.166 Mindong Rd,
Pudong, Shanghai,201209
China

Tel: +86 (0)21 6163 0930
Fax: +86 (0)21 6163 0930
Email: jerrys@fpevalves.com



www.fpevalves.com