



# Spin-Clean™ Oil Cleaning Centrifuge Model 75, 75-1

Datasheet

## Including:

- Parts List
- Installation and Operation
- Service Instructions

## Features and Benefits

- True centrifuge
- Reduces hazardous waste
- Extends oil and filter life
- Removes solid below one Micron
- Diagnostic tool
- User friendly
- Easy installation
- Rugged construction



## Parts List

### Models 75 and 75-1

Centrifuge Model 75 (without cut-out valve assembly) ----- 75  
 Centrifuge Model 75-1 (with cut-out valve assembly) ----- 75-1

### Parts List

Description	Part No.
<b>Cover Assembly (no clamp)</b> -----	<b>C75-CA</b>
Cover Nut -----	C75-13
Seal-Cover Nut -----	C75-12
Cover -----	C75-14
Snap Ring, Cover Nut -----	C75-18
<b>Centrifuge Turbine Assembly</b> -----	<b>C75-TA</b>
Nut-Turbine -----	C75-11
Cover-Turbine -----	C75-03
Seal-Turbine (2 req'd) -----	C75-10
Insert-Turbine (Package of 25) -----	C75-24P
Bowl-Turbine -----	C75-02
Baffle-Turbine -----	C75-04
<b>Base, Turbine Assembly (sold as assembly only)</b> -----	<b>C75-BTA</b>
Nozzle-Turbine (2 req'd) -----	C75-19
<b>Model 75 Base Assembly (no clamp or cut-out valve)</b> -----	<b>C75-BA</b>
<b>Model 75-1 Base Assembly (no clamp)</b> -----	<b>C75-1-BA</b>
Seal, Base to Cover -----	C75-15
Model 75 Base/Shaft (sold as assembly only) -----	C75-16-A
Model 75-1 Base/Shaft (sold as assembly only) -----	C75-16-1-A
Cut-out Valve Piston -----	C75-23
Cut-out Valve Spring -----	C75-22
Cut-out Valve Seal -----	C75-21
Cut-out Valve Plug -----	C75-20
Fitting, Inlet 9/16-18 UNF x 1/4 FNPT -----	C75-25

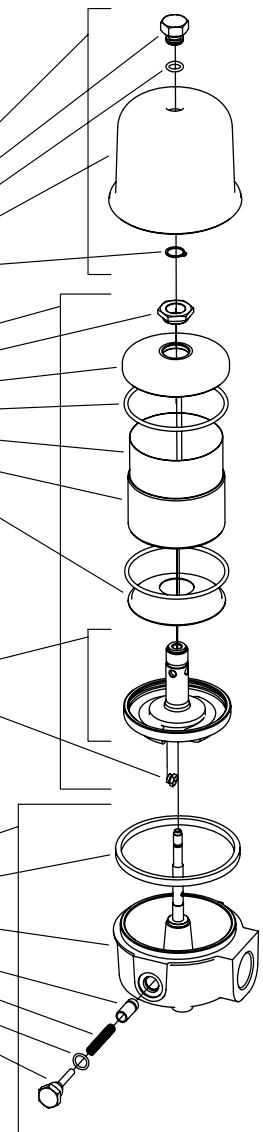

## Installation and Operation

### Oil Supply to Centrifuge

Oil supply should be taken from a source as close to the lube oil pump discharge as possible and on the dirty side of the full flow oil filter. A 1/4" NPT pipe or #6 hose supply should be used for supply with a full-opening ball valve installed in supply line to allow the centrifuge to be isolated for cleaning without shutting the engine down. The centrifuge will operate efficiently at 30 to 90 psig with the preferred pressure of 60 to 80 psig.

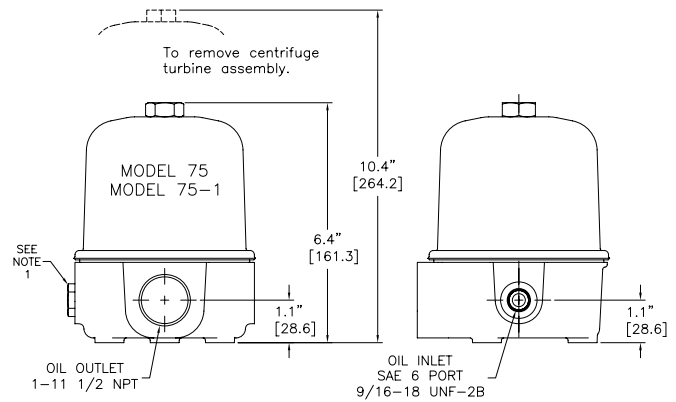

### Clean Oil Return to Sump

The clean oil drain line to the sump should be a 1.0" minimum diameter unrestricted hose or pipe to a 1.0" connection located above the oil level is required. Alternate oil fill openings or drilled-and-tapped holes in crankcase doors are options that can be used. The oil drain line should be free of any shut-off valves. The drain is correct if you can drop in a 1.0" diameter ball and it can freely roll through the drain line into the engine.

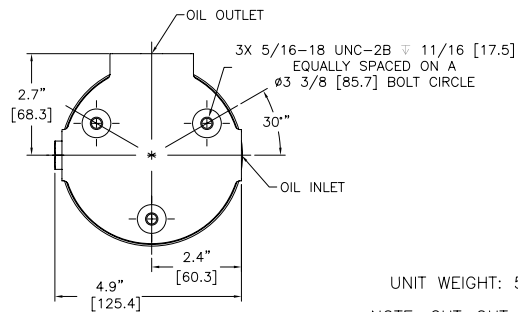

UNIT WEIGHT: 5 LBS [2.3 kg]

NOTE: CUT-OUT VALVE NOT INCLUDED WITH MODEL 75

### Mounting Considerations

SPINCLEAN™ Centrifuges are high-speed devices and should be securely mounted to prevent excessive vibration.

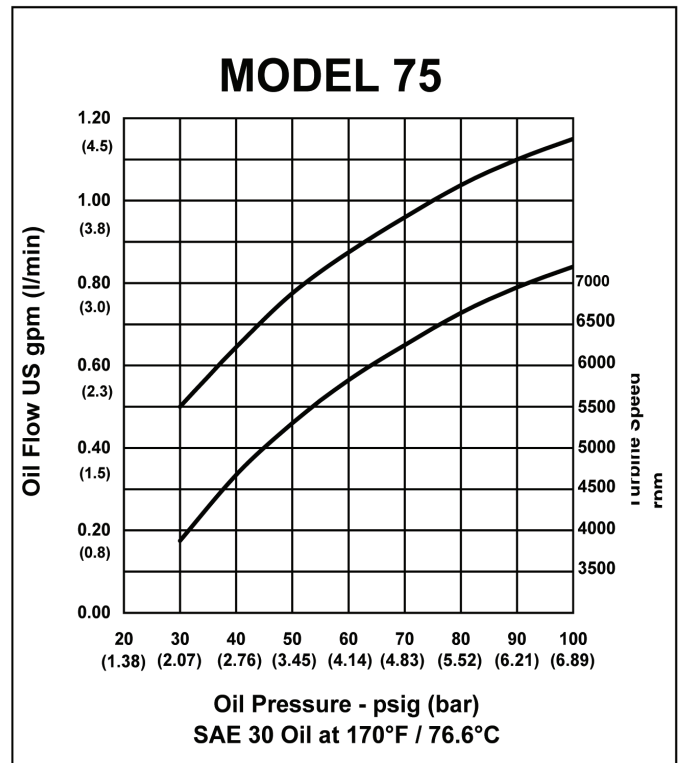

## Service Instructions

1. Shut off oil supply or stop the engine and allow centrifuge turbine assembly to come to a complete stop. **The oil drain line should be free of any shut-off valves.**

2. Unscrew cover and remove cover assembly.

3. Lift the turbine assembly one inch and allow the oil to completely drain out of the nozzles before removing completely.

4. Remove turbine nut, **Part # C75-11**. Carefully separate the turbine assembly. **DO NOT strike the bushings with or against a hard surface or damage will result.**

5. Remove lower turbine bowl seal, **Part # C75-10**, and baffle, **Part # C75-04**.

6. Carefully remove the solids cake from the turbine bowl, **Part # C75-02**, taking care not to damage the turbine bowl. Thoroughly wash away all traces of the solids cake to insure maintaining turbine assembly balance.

7. Thoroughly clean all other turbine parts. Check turbine nozzles, **Part # C75-19**, and make sure they are unrestricted. Replace turbine bowl seals, **Part # C75-10**. Examine top and bottom bearings for excessive wear. Replace turbine base assembly, **Part # C75-BTA**, if diameters exceed 0.317" (8.1 mm) top or 0.396" (10.1 mm) bottom.

8. Seat baffle in turbine base and install lower turbine bowl seal, **Part # C75-10**. Install turbine insert, **Part # C75-24**, inside turbine bowl. Reassemble the turbine assembly tightening the turbine nut, **Part # C75-11** securely to a torque value of 10-15 in-lbs.

9. Examine stationary shaft journals for damage or excessive wear. Replace base assembly, **Part # C75-BA**, complete with stationary shaft if diameter is less than 0.312" (7.9 mm) top or 0.391" (9.9 mm) bottom. The stationary shaft is permanently installed and cannot be replaced.

10. Coat the stationary shaft with clean oil. Install the turbine assembly on the stationary shaft, being careful not to damage bearings. Spin turbine assembly on the stationary shaft and make sure it spins freely and unrestricted.

**Model 75-1 only:** Remove, clean and inspect the idle-cut-out-valve assembly and mating bore in housing. The piston should move freely.

11. Clean and inspect cover assembly, **Part # C75-CA**, and make sure the cover nut seal, **Part # C75-12**, is not leaking. If necessary, replace the seal by removing the cover nut snap ring, **Part # C75-18**, and remove the cover nut with seal from the cover.

12. Replace the base to cover seal, **Part # C75-15**.

13. Replace the cover assembly and tighten the cover nut by hand pressure plus another half turn. Make sure the cover seats evenly around the base to insure proper crush on cover to base seal to prevent oil leaks.

14. Turn on oil supply to the centrifuge. With centrifuge in operation, check complete installation for oil leaks or excessive vibration. If excessive vibration exists then disassemble, inspect and reassemble.

Note: All centrifuge turbines are factory tested for balance before leaving the factory. An out-of-balance condition can occur as a result of uneven build-up of dirt cake in the bowl or as a result of excessive bearing or stationary shaft wear. Depending on conditions, wear will eventually take place on the stationary shaft and bearings, requiring replacement of the appropriate assemblies.

---

**Americas**

Global Headquarters  
Fluid Power Energy Inc  
W229 N591 Foster Court  
Waukesha, WI 53186  
USA

Tel: +1 262-548-6220  
Fax: +1 262-548-6239  
Email: [fpeinfo@fpevalves.com](mailto:fpeinfo@fpevalves.com)

**Europe, Middle East, Africa,  
India, Russia & Asia Pacific**

Fluid Power Energy Inc  
Steinackerstraße 20  
D-79576 Weil am Rhein  
Germany

Tel: +49 (0)7621 940 9990  
Fax: +49 (0)7621 940 99940  
Email: [info@fpevalves.de](mailto:info@fpevalves.de)

**Peoples Republic of China**

FPE (Shanghai) Industry Co., Ltd  
2F 5#Building No.166 Mindong Rd,  
Pudong, Shanghai,201209  
China

Tel: +86 (0)21 6163 0930  
Fax: +86 (0)21 6163 0930  
Email: [jerrys@fpevalves.com](mailto:jerrys@fpevalves.com)



[www.fpevalves.com](http://www.fpevalves.com)