



Spin-Clean™ Oil Cleaning Centrifuge Model 150

Datasheet

Including:

- Parts List
- Installation and Operation
- Service Instructions

Features and Benefits

- True centrifuge
- Reduces hazardous waste
- Extends oil and filter life
- Removes solid below one Micron
- Diagnostic tool
- User friendly
- Easy installation
- Rugged construction



Parts List

Model 150

Centrifuge Model 150

Description	Part No.
Cover Assembly (no clamp)	C150-CA
Cover Nut	C75-13
Seal-Cover Nut	C75-12
Cover	C150-14
Snap Ring, Cover Nut	C75-18
Centrifuge Turbine Assembly	C150-TA
Nut-Turbine	C75-11
Cover-Turbine	C150-03
Seal-Turbine (2 req'd)	C150-10
Insert-Turbine (Package of 25)	C150-24P
Bowl-Turbine	C150-02
Baffle-Turbine	C150-04
Base, Turbine Assembly (sold as assembly only)	C150-BTA
Nozzle-Turbine (2 req'd)	C150-19
Cover Clamp	C150-25
Base Assembly (no clamp)	C150-BA
Seal, Base to Cover	C150-15
Base/Shaft (sold as assembly only)	C150-16-A
Cut-out Valve Snap Ring	1690
Cut-out Valve Retainer	C150-22
Cut-out Valve Spring	C150-23
Cut-out Valve Plug	C150-21
Seal, Cut-out Valve	C1000-29
Cut-out Valve Body	C150-20
Fitting, Inlet, 3/4-16 UNF x 1/2" FNPT	C150-26

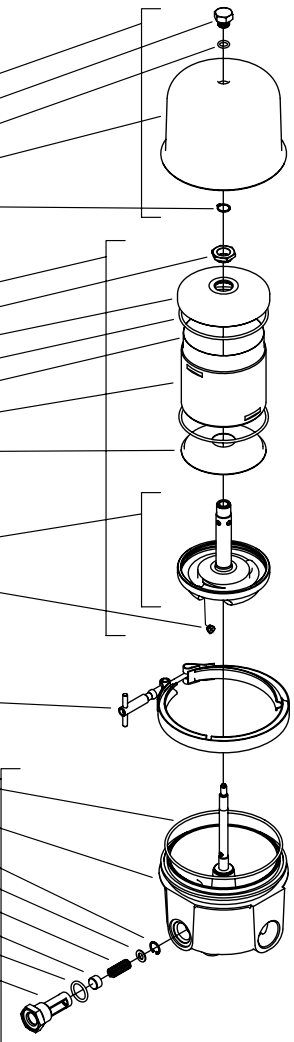

Installation and Operation

Oil Supply to Centrifuge

Oil supply should be taken from a source as close to the lube oil pump discharge as possible and on the dirty side of the full flow oil filter. A 1/4" NPT pipe or #6 hose supply should be used for supply with a full-opening ball valve installed in supply line to allow the centrifuge to be isolated for cleaning without shutting the engine down. The centrifuge will operate efficiently at 30 to 90 psig with the preferred pressure of 60 to 80 psig.

Clean Oil Return to Sump

The clean oil drain line to the sump should be a 1.0" minimum diameter unrestricted hose or pipe to a 1.0" connection located above the oil level is required. Alternate oil fill openings or drilled-and-tapped holes in crankcase doors are options that can be used. The oil drain line should be free of any shut-off valves. The drain is correct if you can drop in a 1 1/4" diameter ball and it can freely roll through the drain line into the engine.

Mounting Considerations

SPINCLEAN™ Centrifuges are high-speed devices and should be securely mounted to prevent excessive vibration.

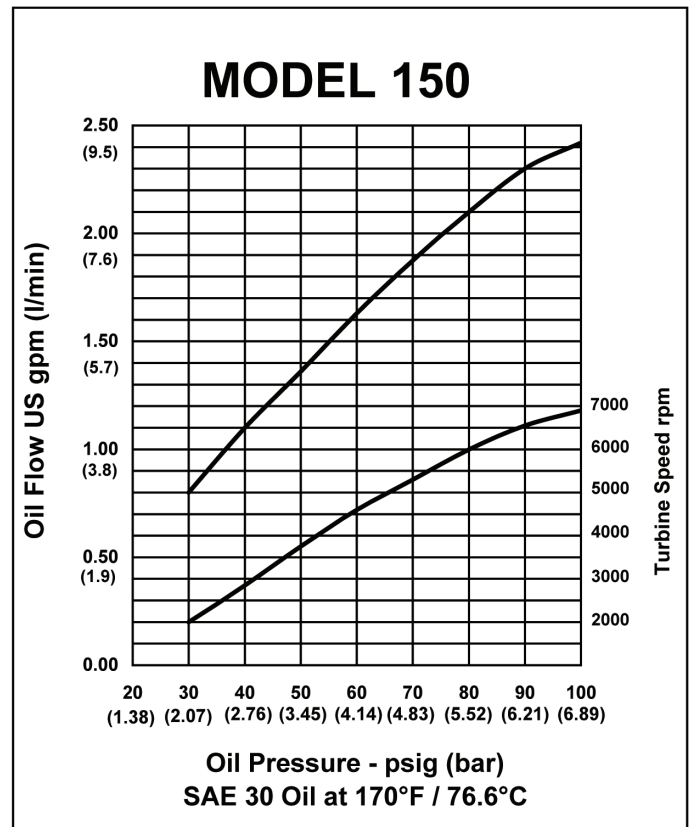
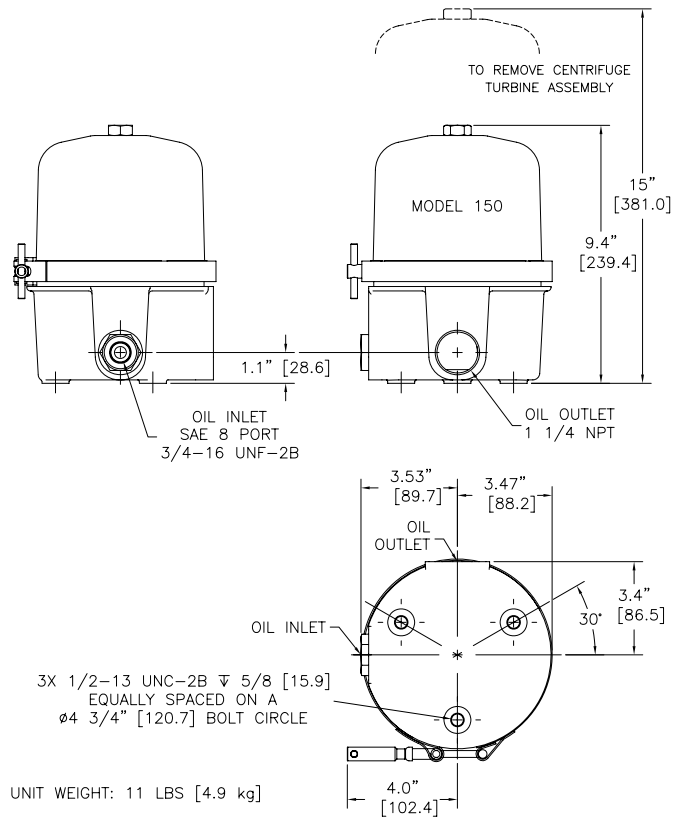

Service Instructions

1. Shut off oil supply or stop the engine and allow centrifuge turbine assembly to come to a complete stop. **The oil drain line should be free of any shut-off valves.**
2. Unscrew cover and remove cover assembly.
3. Lift the turbine assembly one inch and allow the oil to completely drain out of the nozzles before removing completely.
4. Remove turbine nut, **Part # C150-11**. Carefully separate the turbine assembly. DO NOT strike the bushings with or against a hard surface or damage will result.
5. Remove lower turbine bowl seal, **Part # C150-10**, and baffle, **Part # C150-04**.
6. Carefully remove the solids cake from the turbine bowl, **Part # C150-02**, taking care not to damage the turbine bowl. Thoroughly wash away all traces of the solids cake to insure maintaining turbine assembly balance.
7. Thoroughly clean all other turbine parts. Check turbine nozzles, **Part # C150-19**, and make sure they are unrestricted. Replace turbine bowl seals, **Part # C150-10**. Examine top and bottom bearings for excessive wear. Replace turbine base assembly, **Part # C150-BTA**, if diameters exceed 0.317" (8.1 mm) top or 0.396" (10.1 mm) bottom.
8. Seat baffle in turbine base and install lower turbine bowl seal, **Part # C150-10**. Install turbine insert, **Part # C150-24**, inside turbine bowl. Reassemble the turbine assembly tightening the turbine nut, **Part # C150-11** securely to a torque value of 10 - 15 in lbs.
9. Examine stationary shaft journals for damage or excessive wear. Replace base assembly, **Part # C150-BA**, complete with stationary shaft if diameter is less than 0.312" (7.9 mm) top or 0.391" (9.9 mm) bottom. The stationary shaft is permanently installed and cannot be replaced.
10. Coat the stationary shaft with clean oil. Install the turbine assembly on the stationary shaft, being careful not to damage bearings. Spin turbine assembly on the stationary shaft and make sure it spins freely and unrestricted.
11. Clean and inspect cover assembly, **Part # C150-CA**, and make sure the cover nut seal, **Part # C150-12**, is not leaking. If necessary, replace the seal by removing the cover nut snap ring, **Part # C150-18**, and remove the cover nut with seal from the cover.
12. Replace the base to cover seal, **Part # C150-15**.
13. Replace the cover assembly and tighten the cover nut by hand pressure plus another half turn. Make sure the cover seats evenly around the base to insure proper crush on cover to base seal to prevent oil leaks.
14. Remove cut-out valve body, **Part # C150-20**, from cast base, **Part # C150-16**. Replace cut-out valve seal, **Part # C1000-29**. Inspect assembly to make sure cut-out valve plug, **Part # C150-21**, is seated against the cut-out valve body. Replace cut-out valve assembly into base securely to a torque value of 10-15 in lbs.

Americas

Global Headquarters
Fluid Power Energy Inc
W229 N591 Foster Court
Waukesha, WI 53186
USA

Tel: +1 262-548-6220
Fax: +1 262-548-6239
Email: fpeinfo@fpevalves.com

**Europe, Middle East, Africa,
India, Russia & Asia Pacific**

Fluid Power Energy Inc
Steinackerstraße 20
D-79576 Weil am Rhein
Germany

Tel: +49 (0)7621 940 9990
Fax: +49 (0)7621 940 99940
Email: info@fpevalves.de

Peoples Republic of China

FPE (Shanghai) Industry Co., Ltd
2F 5#Building No.166 Mindong Rd,
Pudong, Shanghai,201209
China

Tel: +86 (0)21 6163 0930
Fax: +86 (0)21 6163 0930
Email: jerrys@fpevalves.com



www.fpevalves.com